



ILLINOIS PASSENGER RAIL

CHICAGO TO ROCKFORD

Presentation to Greater Rockford Arab Chamber of
Commerce

November 6, 2024



IDOT Office of Intermodal Project Implementation Team

Abigail Robinson, PE

Rail Project
Engineer



Scott Speegle

Passenger
Rail and Transit
Communications
Manager



Elliot Ramos, PE

Bureau Chief
of Passenger
Rail Corridor
Management



Overview

- History and Program Timeline
- Anticipated Service
- Project Route Map
- Project Roles
- Stakeholder Coordination
- Project Funding
- Proposed Improvements on the Metra Segment and Union Pacific Segment
- Next Steps for Stations, Grade Crossings and Track Improvements
- Environmental Resources
- Public Involvement
- Ways to Stay Involved and What's Next?

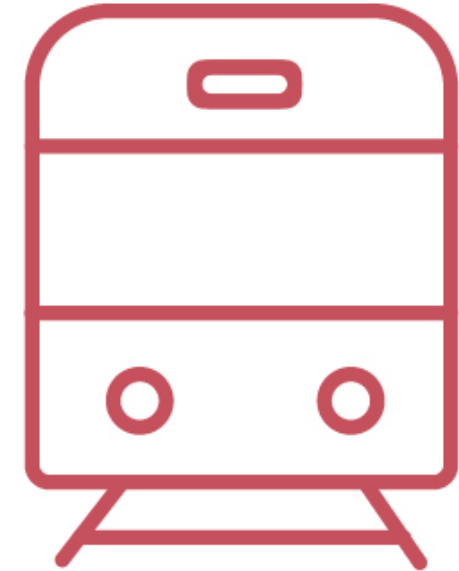

History of Service Between Chicago and Rockford

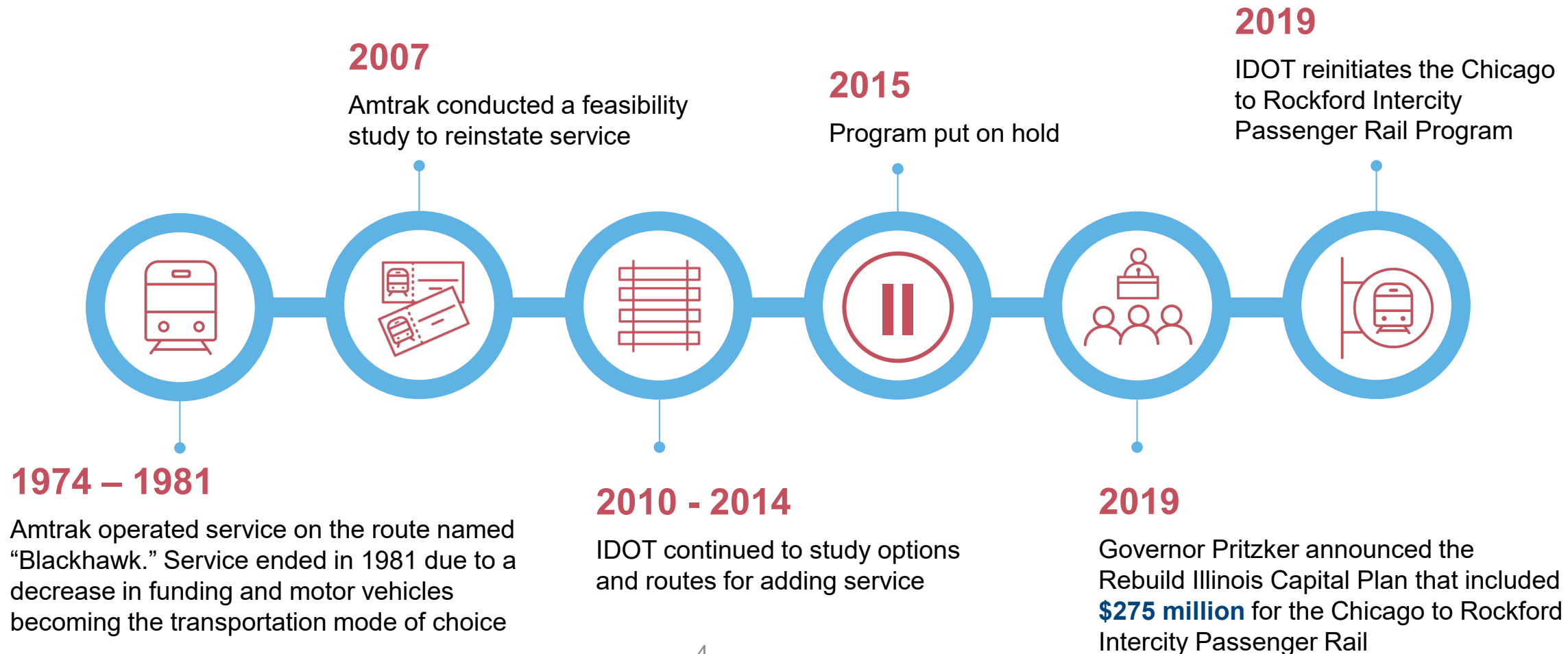

Program Timeline

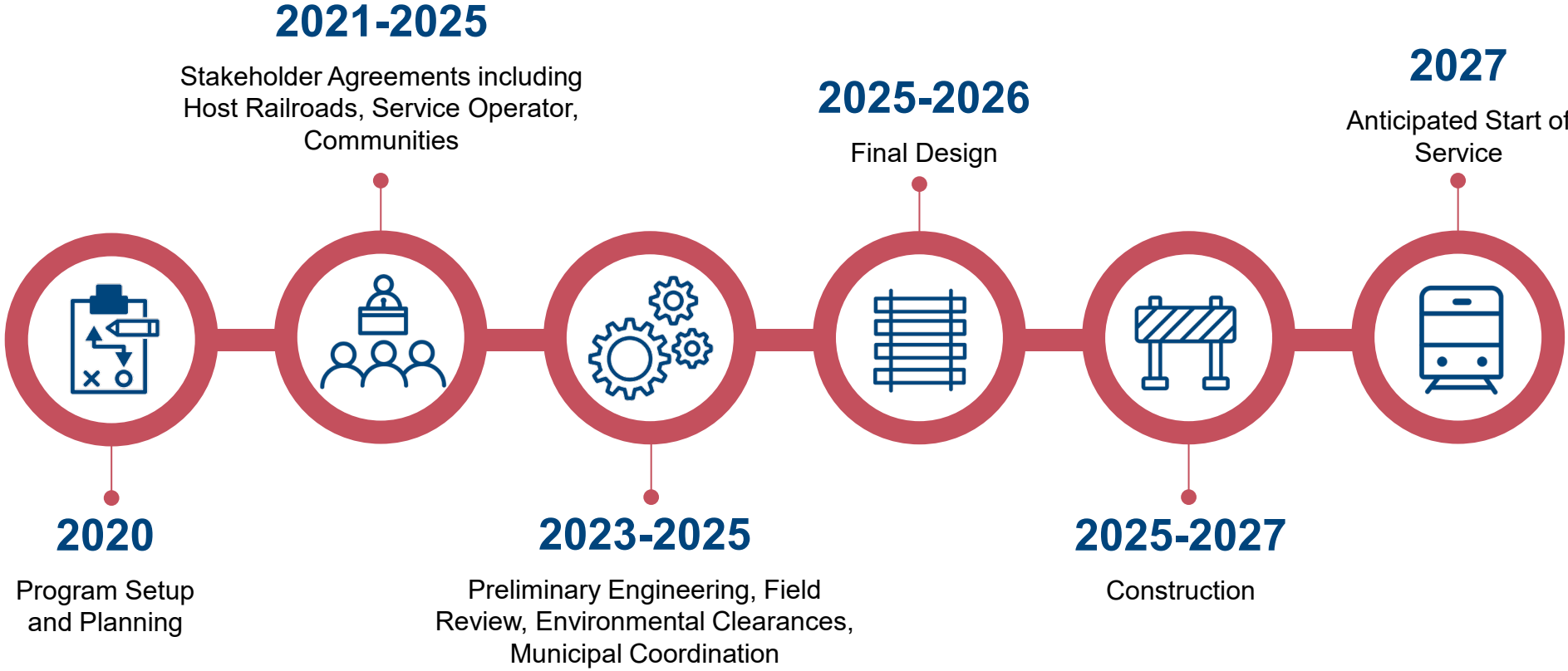

Public Outreach:

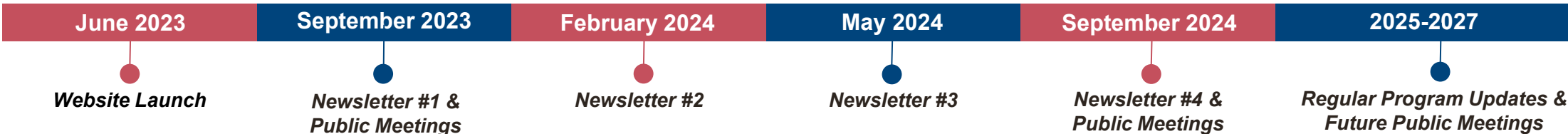

Anticipated Service

- Maximum speeds of **79 MPH**
- Intercity passenger rail service between Chicago and Rockford (**approximately 90 miles**)
- Metra as operator for the state-supported service

Two round trips per day:

- AM trips: Rockford to Chicago and Chicago to Rockford
- PM trips: Rockford to Chicago and Chicago to Rockford
- Travel time of approximately **two hours**
- Ticketing process and pricing details under review



Project Route Map



MAP KEY

- Metra Milwaukee District West Line
- UPRR Belvidere Subdivision

Service Layer Credits: Sources: Esri, HERE, Garmin, USGS, Intermap, INCREMENT P, NRCan, Esri Japan, METI, Esri China (Hong Kong), Esri Korea, Esri (Thailand), NGCC, (c) OpenStreetMap contributors, and the GIS User Community

Project Roles

Project Lead

Illinois Department of Transportation
Office of Intermodal Project Implementation



Host Railroads

- Metra: from Chicago to Elgin
- Union Pacific: from Elgin to Rockford



Intercity Passenger Rail Service Operator



Community Partners

- Station stakeholders, including: Elgin, Huntley, Belvidere and Rockford
- Public grade crossings stakeholders

Stakeholder Coordination

Stakeholders



Additional stakeholders include communities along the corridor and jurisdictions with grade crossings.

Project Funding



As part of Governor Pritzker's
\$45 billion
Rebuild Illinois Capital Plan.

\$275 million
is being provided for Chicago to
Rockford Intercity Passenger Rail.



Proposed Improvements

Metra Segment

Proposed Improvement to Metra Segment

- **Construction of connection** between Metra and Union Pacific tracks at Big Timber.
- **Station improvements** at Elgin Station (intercity passenger rail service likely to use Chicago St. station).
- New control point with **universal crossovers** at Bartlett.



Segment Operations

- Metra operates Milwaukee District West (MD-W) commuter operations over this busy Metra-owned segment dispatched by Canadian Pacific Kansas City (CPKC).
- CPKC freight services also operate over the segment.

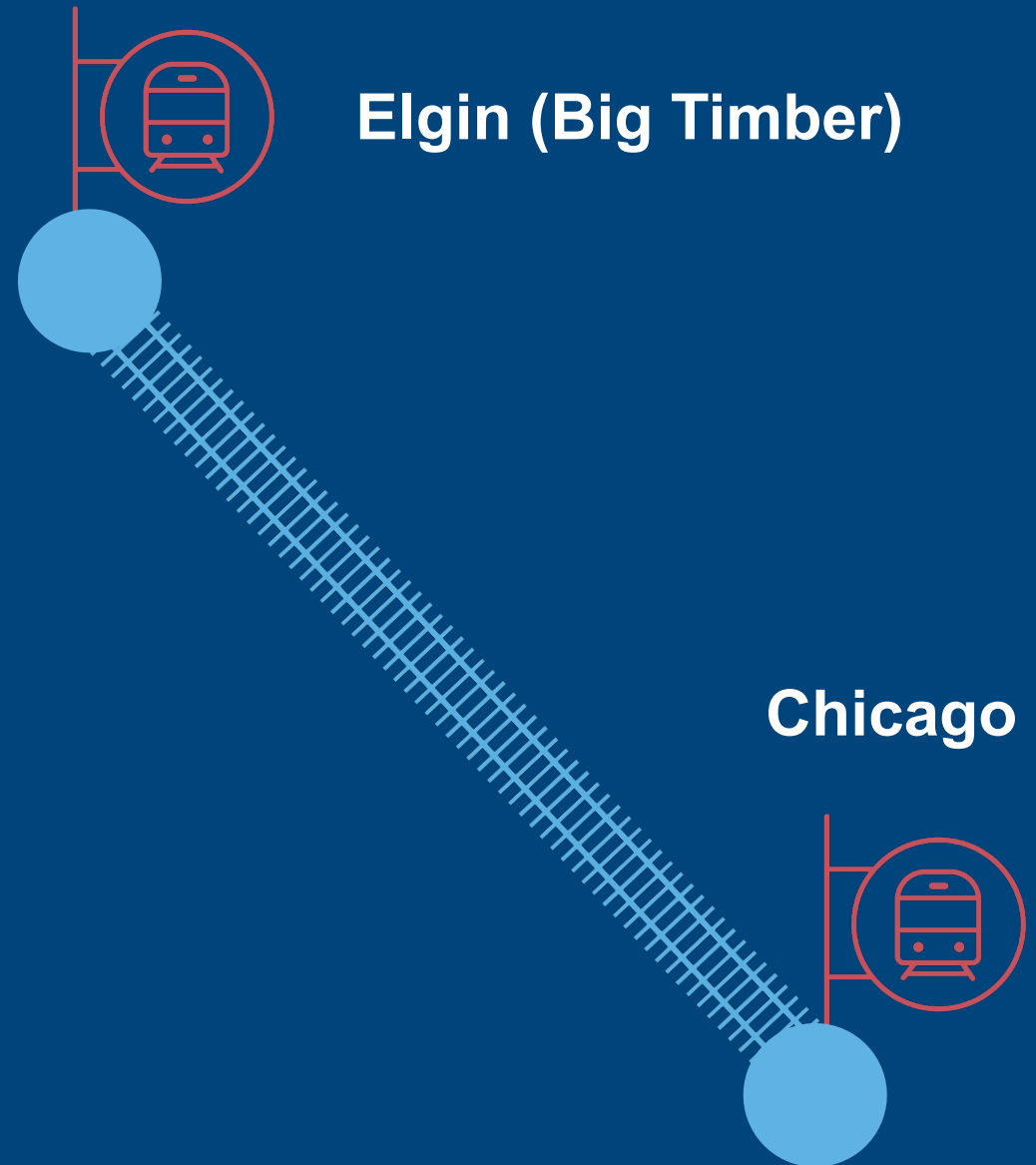



Proposed Improvements

Union Pacific Railroad (UP) Segment

Proposed Improvement to UP Segment

- **Track improvements** to support increasing speeds from existing freight operations (**40 mph or slower**) to passenger rail operations (**up to a maximum of 79 mph**).
- **Construction of connection** between Metra and Union Pacific tracks at Big Timber.
- **Enhance** grade crossing surfaces, highway approaches and warning devices.
- **Evaluate bridge conditions** as needed.
- **Proposed siding** near Marengo.



Segment Operations

- Union Pacific Railroad (UP) owned.
- UP operates one daily round trip freight train between **West Chicago** and **Belvidere** through **Big Timber**.
- A local round trip freight train operates from **Belvidere** to **Huntley** depending on need several days a week.

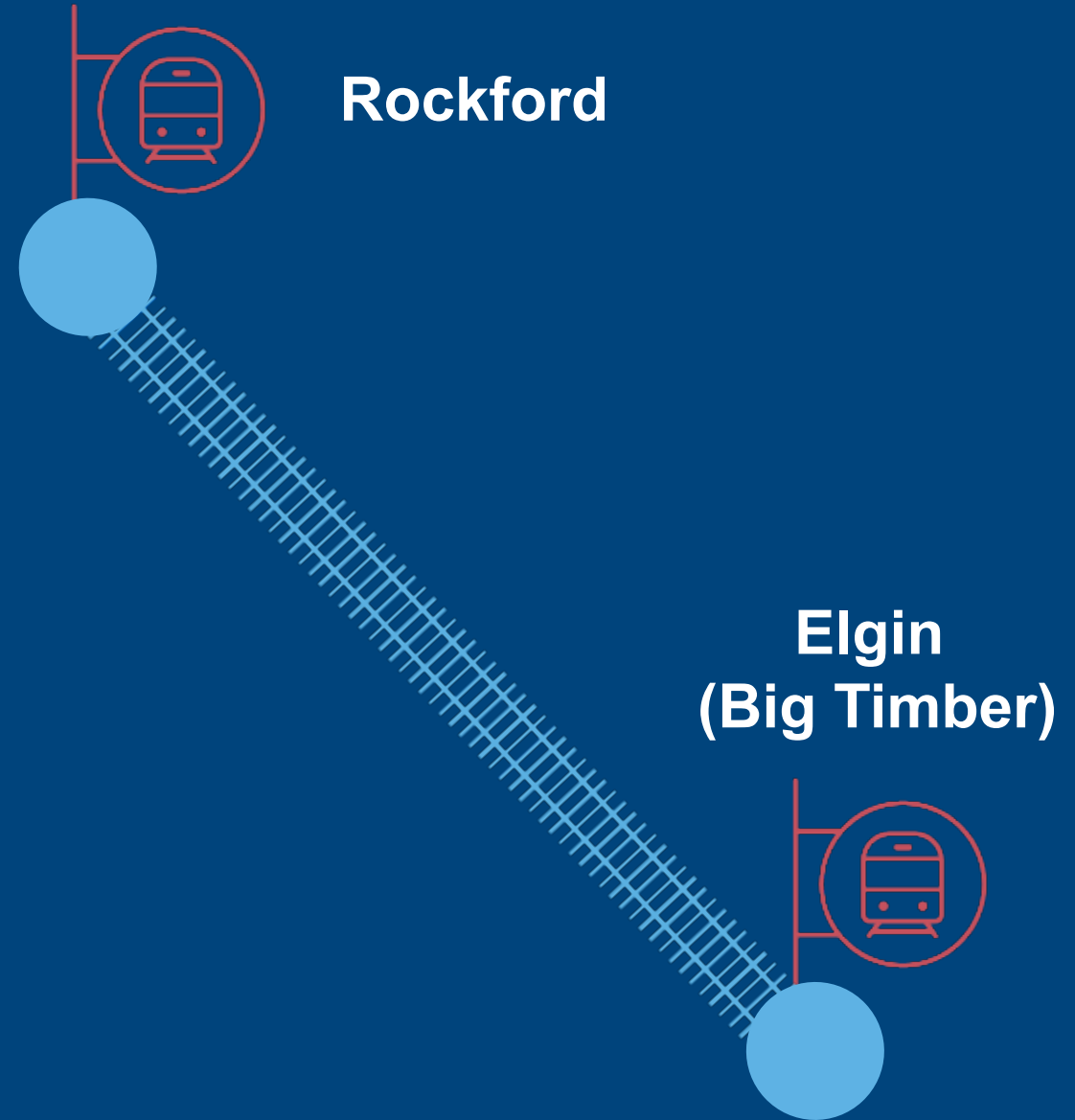

Stations

Proposed station locations for the Intercity Passenger Rail service include:
Chicago, Elgin, Huntley, Belvidere and Rockford.

- Engagement with communities began in **2023**.
- IDOT design team will work with partners to identify preferred site locations and station needs in each community.
- Region 1 Planning Council has worked on station studies in Belvidere and Rockford.



MAP KEY

- Metra Milwaukee District West Line
- UPRR Belvidere Subdivision

Service Layer Credits: Sources: Esri, HERE, Garmin, USGS, Intermap, INCREMENT P, NRCan, Esri Japan, METI, Esri China (Hong Kong), Esri Korea, Esri (Thailand), NGCC, (c) OpenStreetMap contributors, and the GIS User Community

Stations Facilities and Amenities

- Platform for passenger trains
- Passenger waiting shelter
- Passenger seating in shelter and on platform
- Parking
- Bicycle parking
- Site lighting
- Signage
- Passenger Information Displays
- Landscaping, site furnishings and safety fencing



Designs for stations still being developed. Above images shown for illustrative purposes only.

Grade Crossings

- Crossing Diagnostics – on-site review of existing conditions and proposed improvements were performed for each public grade crossing between Elgin and Rockford.
- Diagnostic team included:

**Illinois Commerce
Commission**

**Illinois Department
of Transportation**

Union Pacific Railroad

**Local highway jurisdiction
for each crossing**

- Diagnostic site visits completed spring 2024.



Crossing Improvements

Safety improvements for **public crossings** to include:

- **Two** quadrant gates at crossings without existing active warning systems
- Crossing surface replacements as needed
- Pedestrian gates for crossings with existing sidewalks
- Fencing on railroad right-of-way as needed
- Pavement markings and crossing advance warning signs
- Railroad signal improvements including railroad signal control cabinet placed a minimum of **25 feet** from nearest rail and **30 feet** from roadway travel lane



Example of Active Grade Crossing Warning System for Roadway and Sidewalk

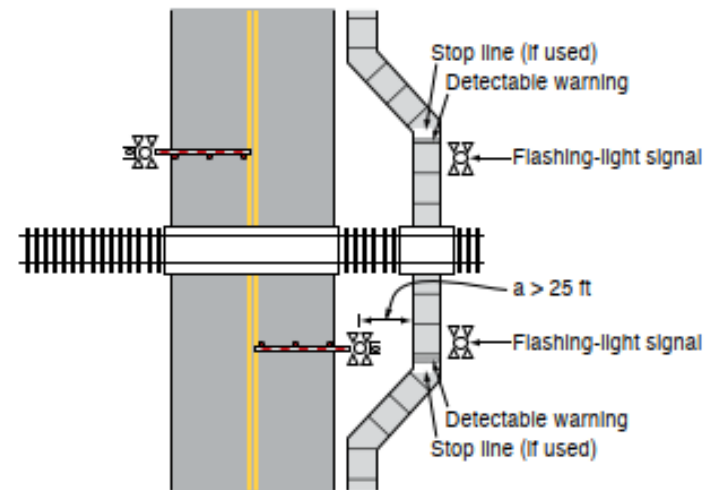
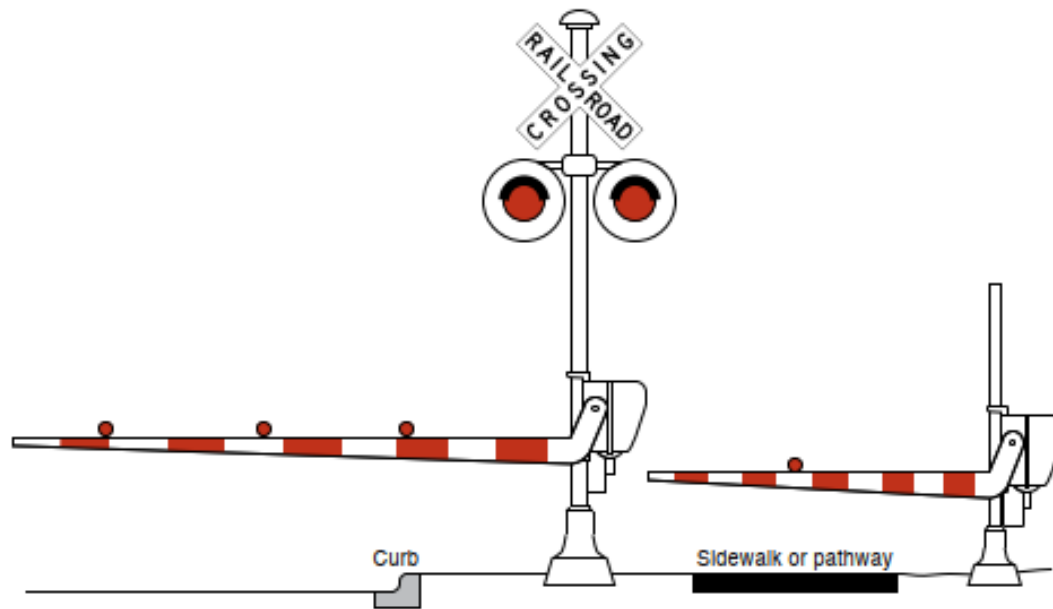

Designs for crossings still being developed. Above images shown for illustrative purposes only.

Fencing

- Fence may be required to secure the railroad property and prevent trespass
- Fencing type to be determined
- Fencing limits to be reviewed as designs progress



Designs for fencing still being developed.

Above image shown for illustrative purposes only.

Track Improvements

- **Field surveys in 2024**
- **Goal is to stay within UP property**
- **Allowable speeds**
 - Track improvements to reach **maximum speeds of 79 mph** for passenger trains

Maximum permitted speeds for **current track conditions**, depending on location, range from:

- FRA Class 1 – **10 mph** freight/**15 mph** passenger
- FRA Class 2 – **25 mph** freight/**30 mph** passenger
- FRA Class 3 – **40 mph** freight/**60 mph** passenger

Maximum permitted speeds with **track improvements** will be:

- FRA Class 4 – **60 mph** freight/**80 mph** passenger



Existing Conditions

Environmental Resources

- Identification of environmental resources in the project area
- Conducting environmental surveys in 2024 and 2025
- Regular meetings ongoing with McHenry County Conservation District



Public Involvement

SEPTEMBER 2024 PUBLIC MEETINGS

350+

People Attended
Public Meetings

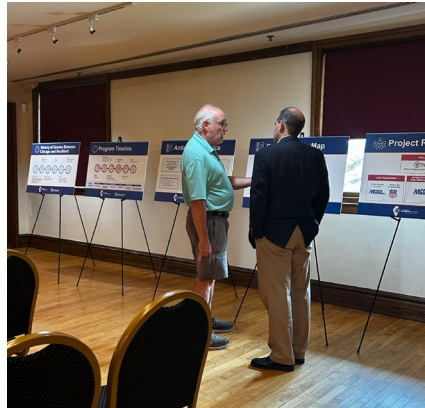

850+

Mailing List Subscribers

270+

Public Comments Received



ISSUE IV • September 2024

ILLINOIS PASSENGER RAIL
CHICAGO TO ROCKFORD

WELCOME

Thank you for your interest in the Chicago to Rockford Intercity Passenger Rail Program!

We're excited to keep you updated on project developments, upcoming meetings and events, and we look forward to receiving your feedback as the program moves forward.

PROJECT OVERVIEW

Governor JB Pritzker and the Illinois Department of Transportation (IDOT) are partnering with Union Pacific Railroad and Metra to re-establish intercity passenger rail service between Chicago and Rockford, with intermediate stops planned in Elgin, Huntley and Belvidere. This service will provide efficient, safe and reliable transportation operators, with passenger trains traveling at maximum speeds of up to 75 mph, connecting Illinois communities in Cook, Kane, McHenry, Boone and Winnebago Counties.

[Enlarge Map >>](#)

PROJECT UPDATES

You're invited to a Public Information Meeting!

As part of public engagement efforts, IDOT will host a series of public information

PROJECT UPDATES

You're invited to a Public Information Meeting!

As part of public engagement efforts, IDOT will host a series of public information meetings in September to discuss the Chicago to Rockford Intercity Passenger Rail Program. The meetings will provide attendees with program updates and an opportunity to provide input and speak with members of the project team.

All meetings will be hosted in an open-house format so you may attend any time during the dates and times outlined. Copies of the presentation will be available in English and Spanish. All venues are accessible. If you have any questions pertaining to the meeting accommodations, please contact Mary McVain at mmcivain@morrealcomm.com.

[CLICK HERE](#) FOR MEETING DETAILS!

WAYS TO STAY INFORMED

Visit ChicagoToRockfordRail.org to stay up to date about project happenings and to learn more about public involvement opportunities.

To submit a question or comment to IDOT team via email, please contact info@ChicagoToRockfordRail.org.

Share this newsletter with neighbors and friends in your community and encourage them to subscribe to the project newsletter so they can stay informed.

Illinois Department of Transportation For more information, visit ChicagoToRockfordRail.org

Ways to Stay Involved

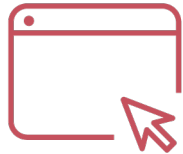

Subscribe to the project mailing list on the project website to receive updates:
www.chicagotorockfordrail.org



To submit a comment via email, please contact: info@chicagotorockfordrail.com



Recommend **organizations** and **businesses** in your area with whom we should engage



SCAN THE QR CODE
to visit the project website.

What's Next?

Preliminary Engineering Design

- Track improvements
- Connection track at Big Timber
- Siding near Marengo
- Crossing improvements
- Stations

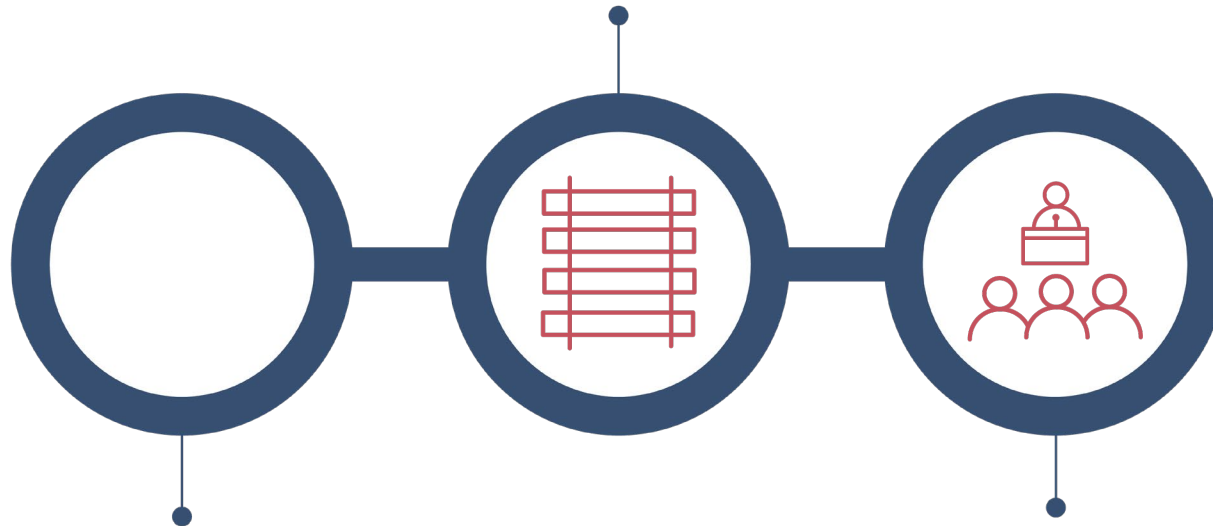

Field Surveys

- Track, crossing and station survey
- Environmental surveys

Agreements

- Intergovernmental agreements between IDOT and communities

Thank you!



Contact:



info@chicagotorockfordrail.com



www.chicagotorockfordrail.org

**ILLINOIS
PASSENGER
RAIL**
CHICAGO TO ROCKFORD